



Plastic-Encapsulate Transistors(NPN)

TO-252W



Features

- AEC-Q101 Qualified and PPAP Capable
- High breakdown voltage margin
- Abnormal leakage current
- High output power
- High secondary breakdown resistance and reliability

Mechanical data

- Case: TO-252W
- Approx. Weight: 0.33g (0.012oz)
- RoHS compliant
- Case Material: “Green” molding compound, UL flammability classification 94V-0, “Halogen-free”.

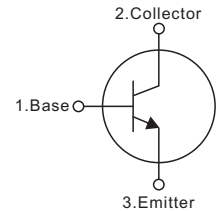
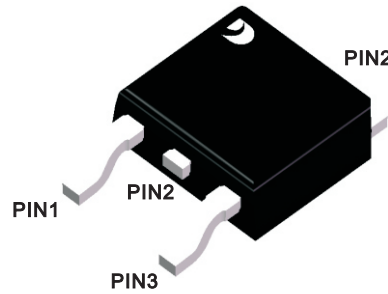

Maximum Ratings (Ta=25°C unless otherwise noted)

Parameter	Symbols	Ratings	Units
Collector-Base Voltage	V_{CBO}	120	V
Collector-Emitter Voltage	V_{CEO}	100	V
Emitter-Base Voltage	V_{EBO}	7	V
Collector Current -Continuous	I_C	6	A
Collector Power Dissipation	P_C	33	W
Operation Junction and Storage Temperature Range	T_J, T_{stg}	-55 ~ +150	°C

Electrical Characteristics (Ta=25°C unless otherwise noted)

Parameter	Symbols	Test conditions	Min	Typ	Max	Units
Collector-base breakdown voltage	V_{CBO}	$I_C=0.1mA, I_E=0$	120			V
Collector-emitter breakdown voltage	V_{CEO}	$I_C=10mA, I_B=0$	100			V
Emitter-base breakdown voltage	V_{EBO}	$I_E=0.1mA, I_C=0$	7			V
Collector cut-off current	I_{CBO}	$V_{CB}=150V, I_E=0$			1	uA
Emitter cut-off current	I_{CEO}	$V_{CE}=120V, I_B=0$			1	uA
Emitter cut-off current	I_{EBO}	$V_{EB}=7V, I_C=0$			1	uA
DC current gain	h_{FE1}	$V_{CE}=5V, I_C=1A$	60		200	
	h_{FE2}	$V_{CE}=2V, I_C=3A$	80			
Collector-emitter saturation voltage	$V_{CE(SAT)}$	$I_C=4A, I_B=0.4A$		0.2	1.5	V
Base-emitter voltage	$V_{BE(SAT)}$	$I_C=4A, I_B=0.4A$			1.0	V



powerIDissipationVs.AAmbient

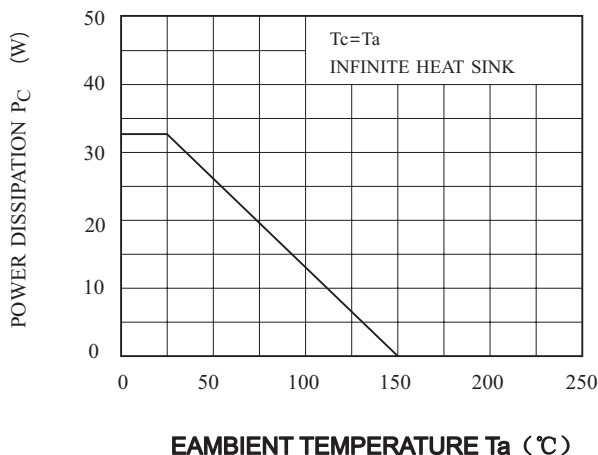

Ic Derating Vs.ccase Temperature

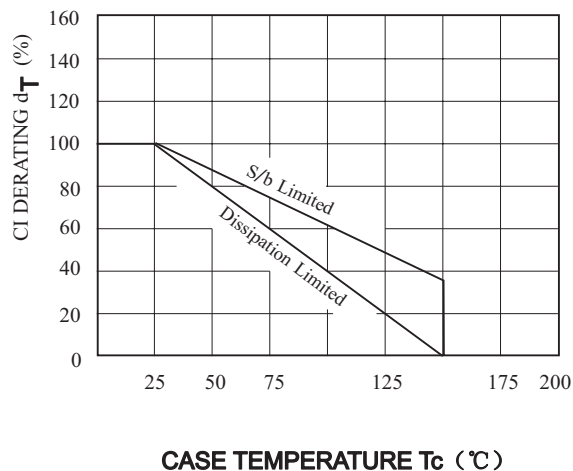

SAFE OPERATING AREA

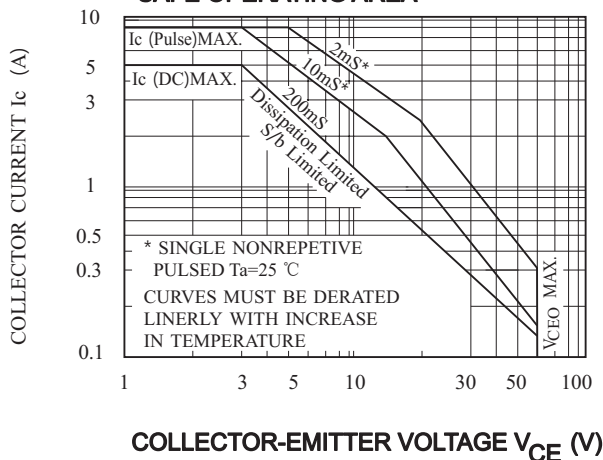

REVERSE BIAS SAFE OPERATING AREA

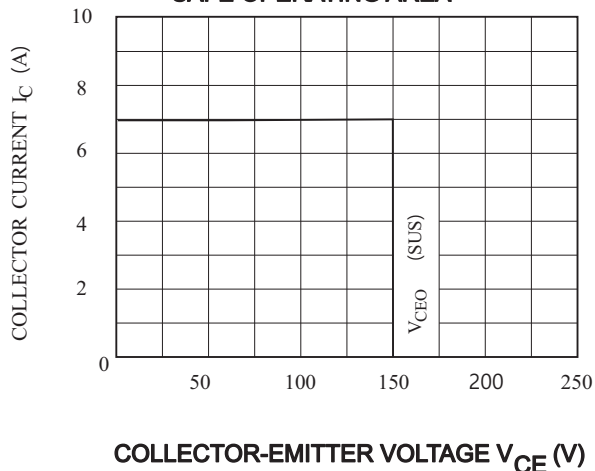

voltage

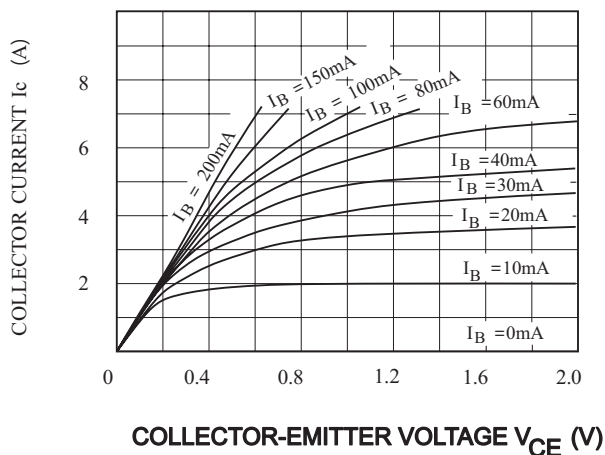

Dc current Gain vs. ccollector current

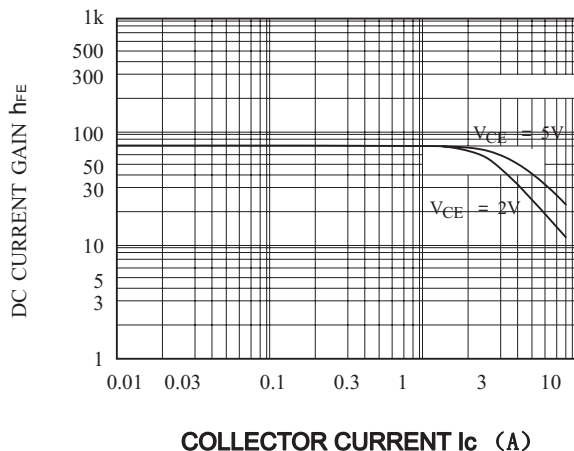

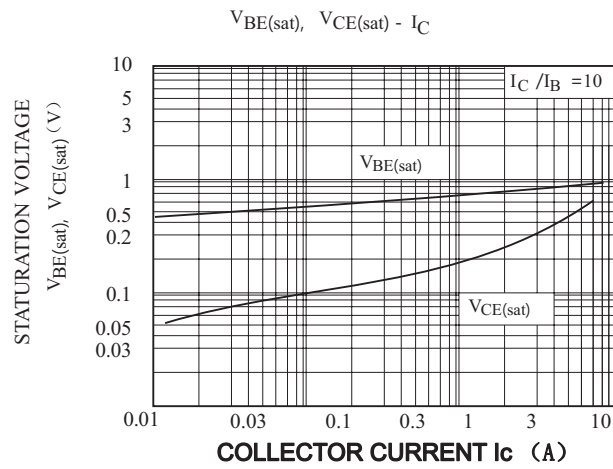



TO-252W(D-PAK) Package Outline Dimensions

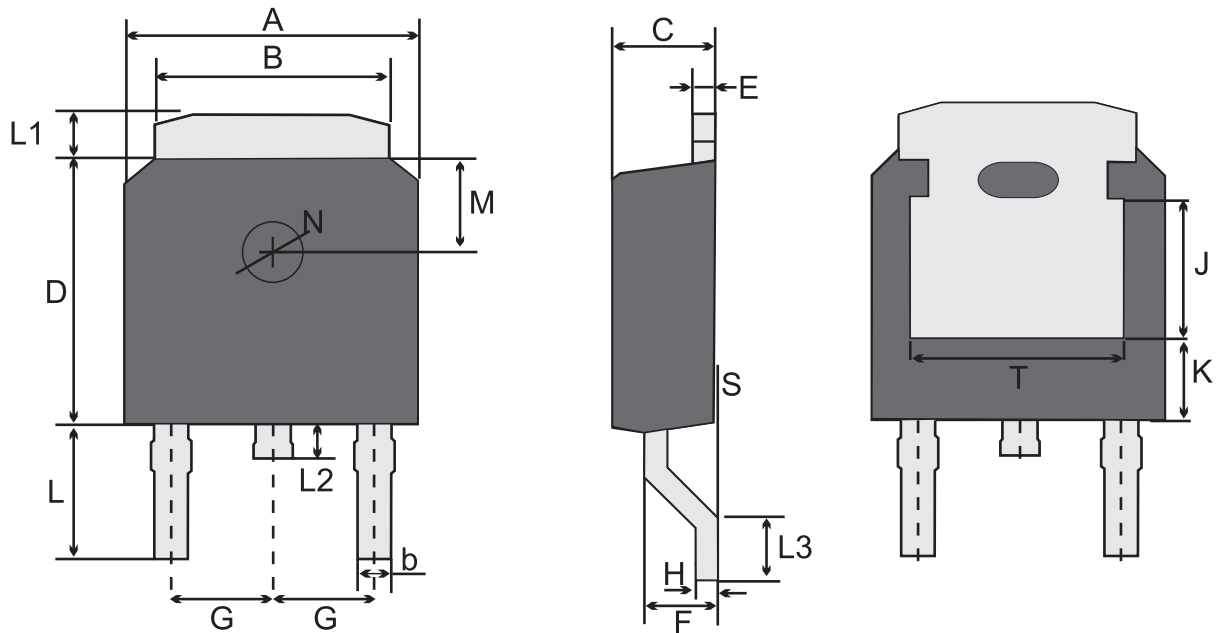

TO-252W(D-PAK)Mechanical data

UNIT		A	B	b	C	D	E	F	G	H	L	L1	L2	L3	S	M	N	J	T	K
mm	max	6.7	5.53	0.86	2.5	6.3	0.61	1.87	2.3 typ.	0.55	3.0	1.2	1.0	1.75	0.1	1.8 typ.	1.3 typ.	3.2 ref.	4.83 ref.	1.8 ref.
	typ	6.6	5.33	0.76	2.3	6.1	0.51	1.57		0.50	2.8	1.0	0.8	1.30	0.05					
	min	6.3	5.13	0.66	2.1	5.9	0.41	1.27		0.45	2.6	0.8	0.6	1.0	/					
mil	max	264	218	34	98	248	24	74	91 typ.	22	118	47	39	69	3.9	71 typ.	51 typ.	126 ref.	190 ref.	71 ref.
	typ	260	210	30	91	240	20	62		20	110	39	31	51	2.0					
	min	248	202	26	83	232	16	50		18	102	31	24	39	/					

Marking

Type number	Marking code
D2SC1C31	D2SC1C31



Important Notice and Disclaimer

Jingdao Microelectronics reserves the right to make changes to this document and its products and specifications at any without notice.

Customers should obtain and confirm the latest product information and specifications before final, purchase or use.

Jingdao Microelectronics makes no warranty, representation or guarantee regarding the suitability of its products for any particular purpose, not does Jingdao Microelectronics assume any liability for application assistance or customer product design.

Jingdao Microelectronics does not warrant or accept any liability with products which are purchased or used for any unintended or unauthorized application.

No license is granted by implication or otherwise under any intellectual property rights of Jingdao Microelectronics.

Jingdao Microelectronics products are not authorized for use as critical components in life support devices or systems without express written approval of Jingdao Microelectronics.